

Caractéristiques techniques
smartroll™ 32-3

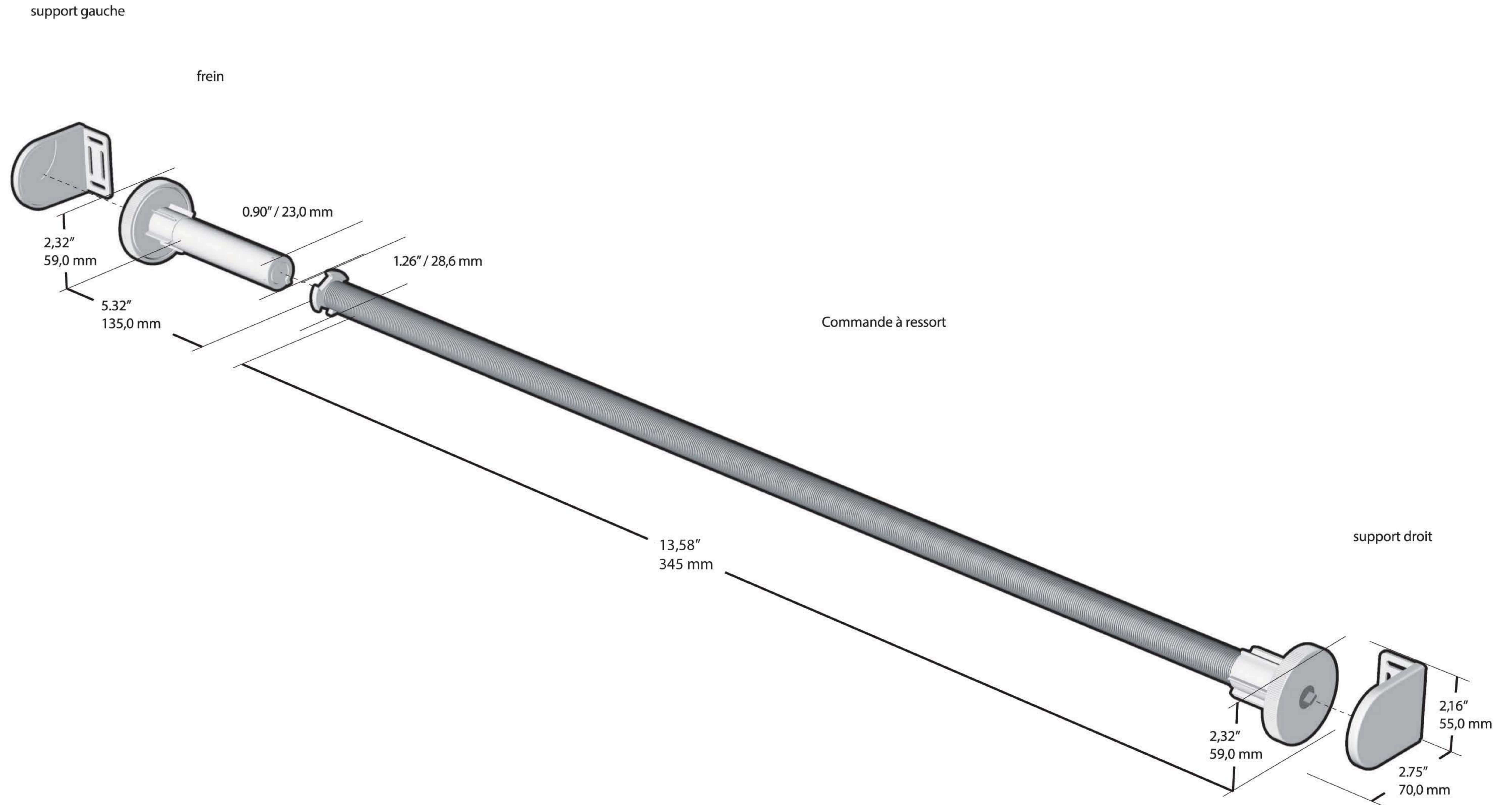

Détails des éléments du mécanisme



Diamètre et profils du tube

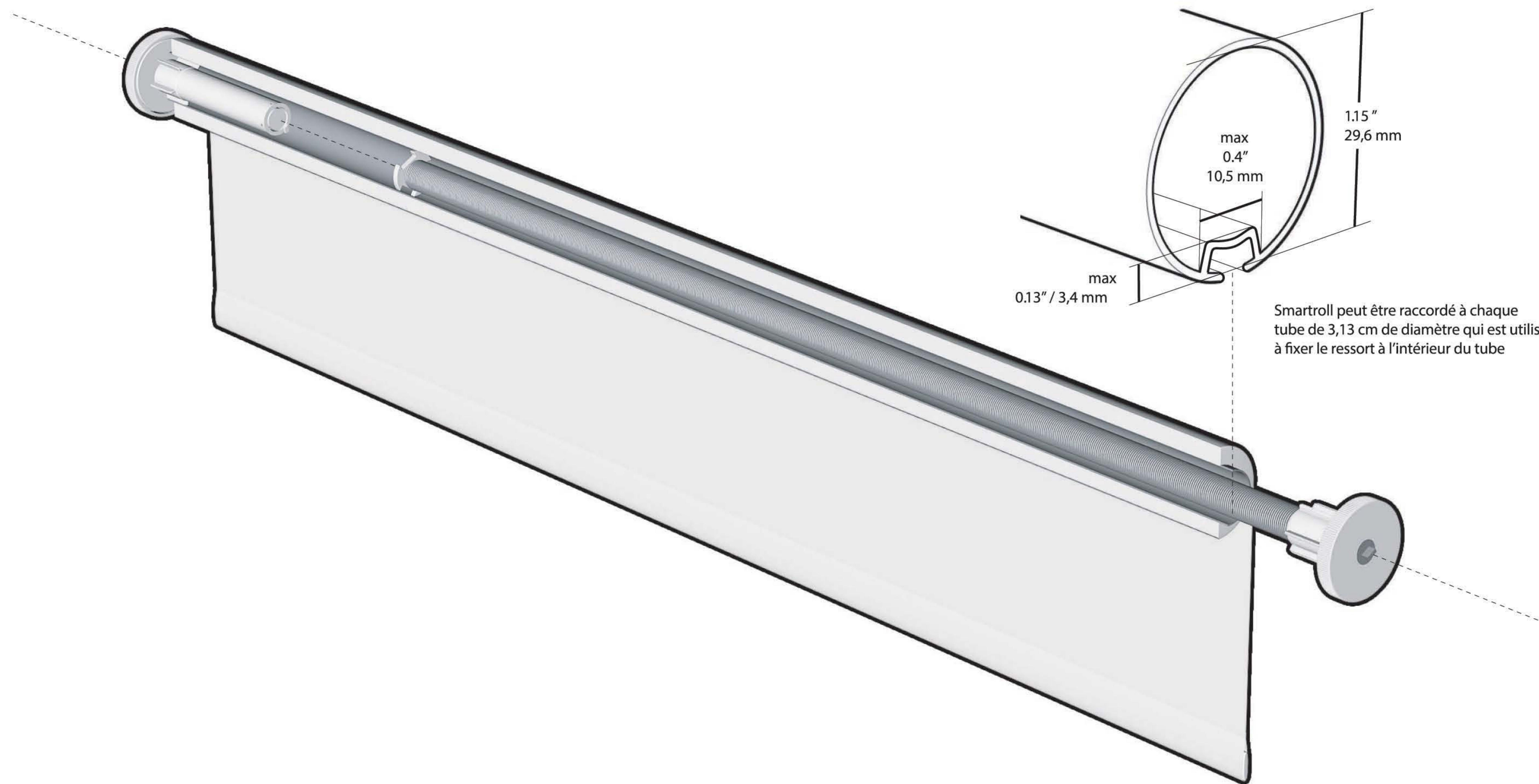

Caractéristiques techniques smartroll™ 32-3

Poids maximum et dimensions du tissu

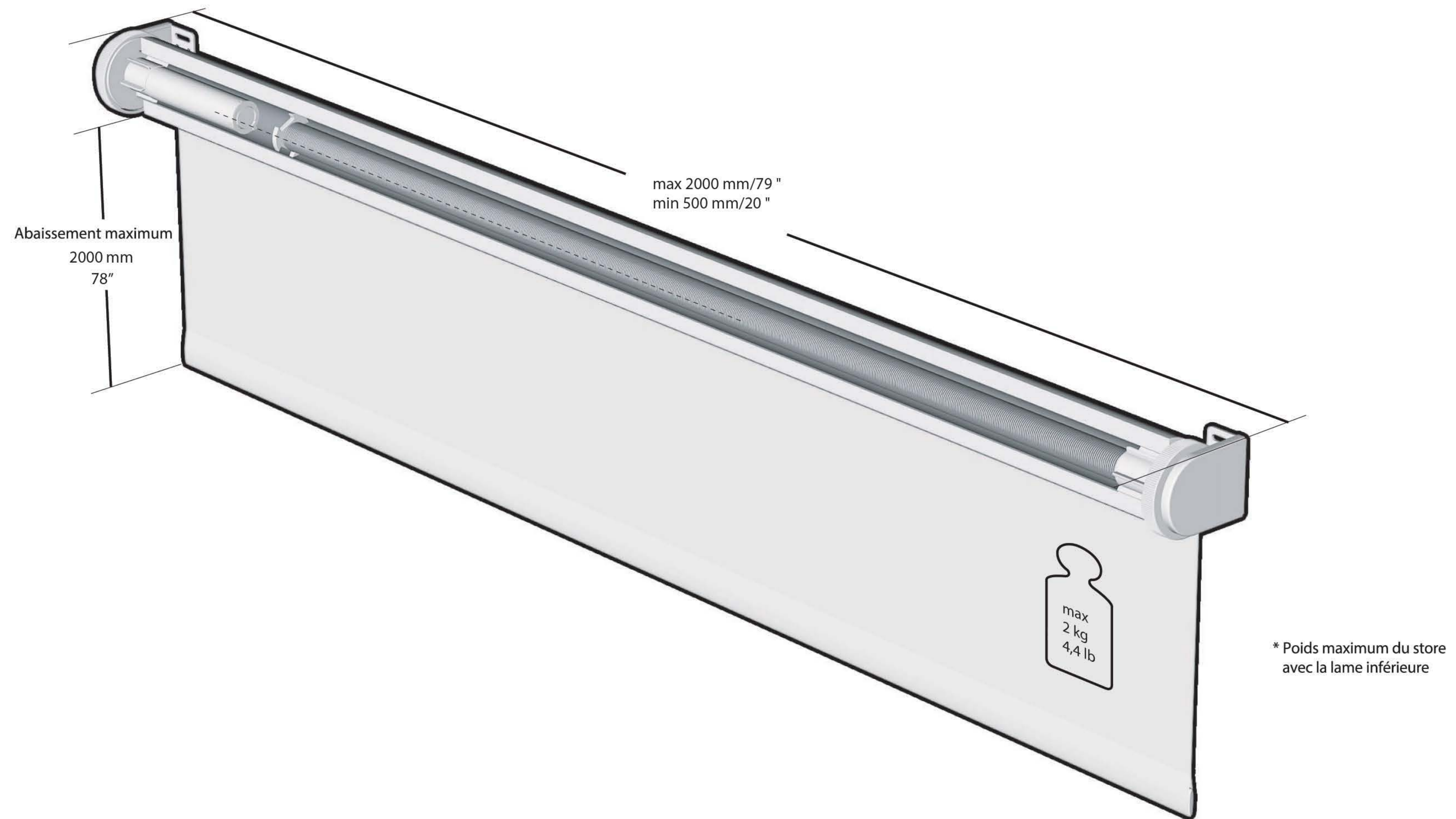

Nombre maximum de tours



Largeur totale u tissu	Nombre de tours recommandé
120	12
140	13
160	14
180	15
200	16
220	17
240	18