

Caractéristiques techniques  
smartroll™ 32-2

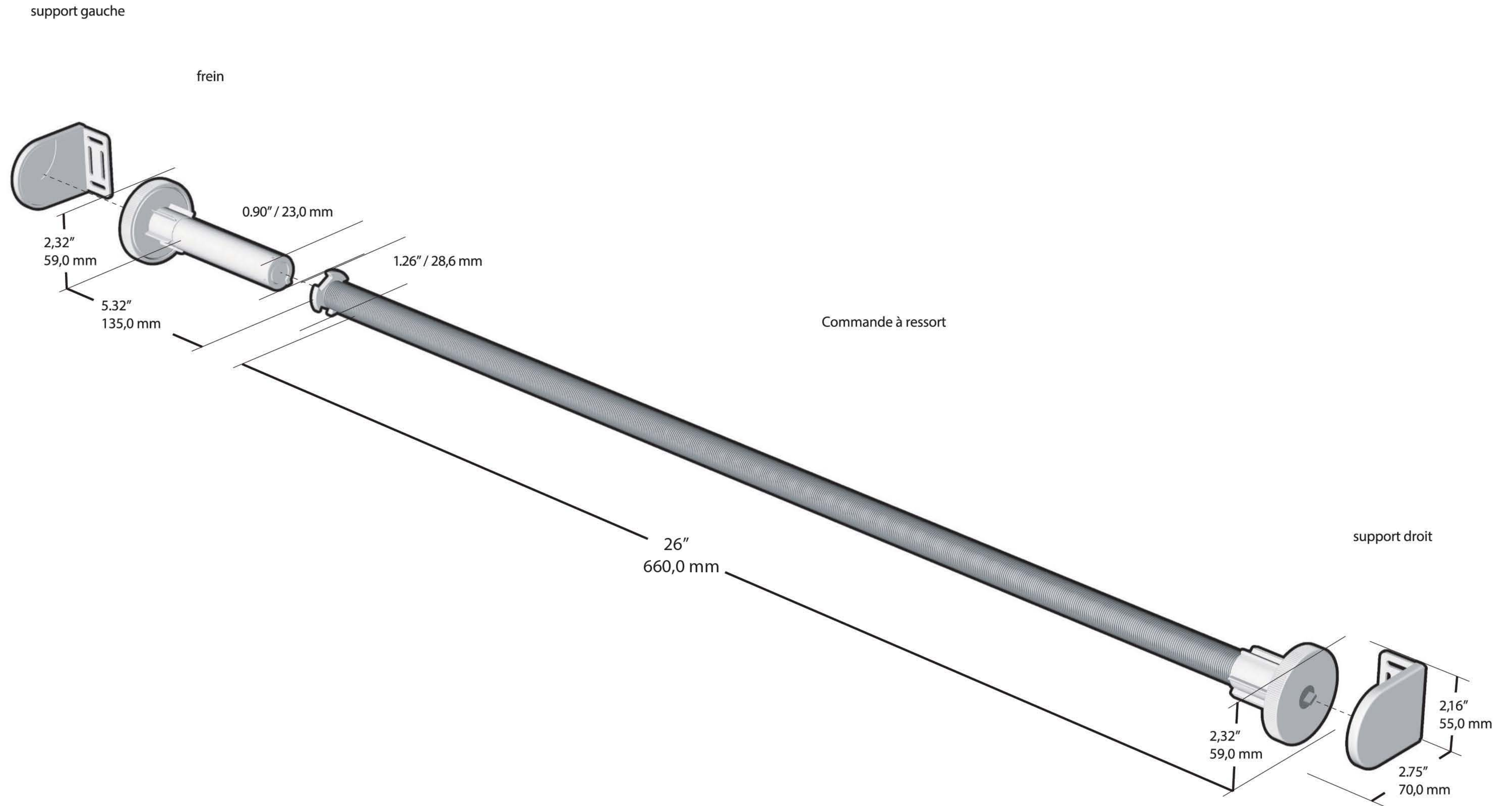

## Détails des éléments du mécanisme



## Diamètre et profils du tube

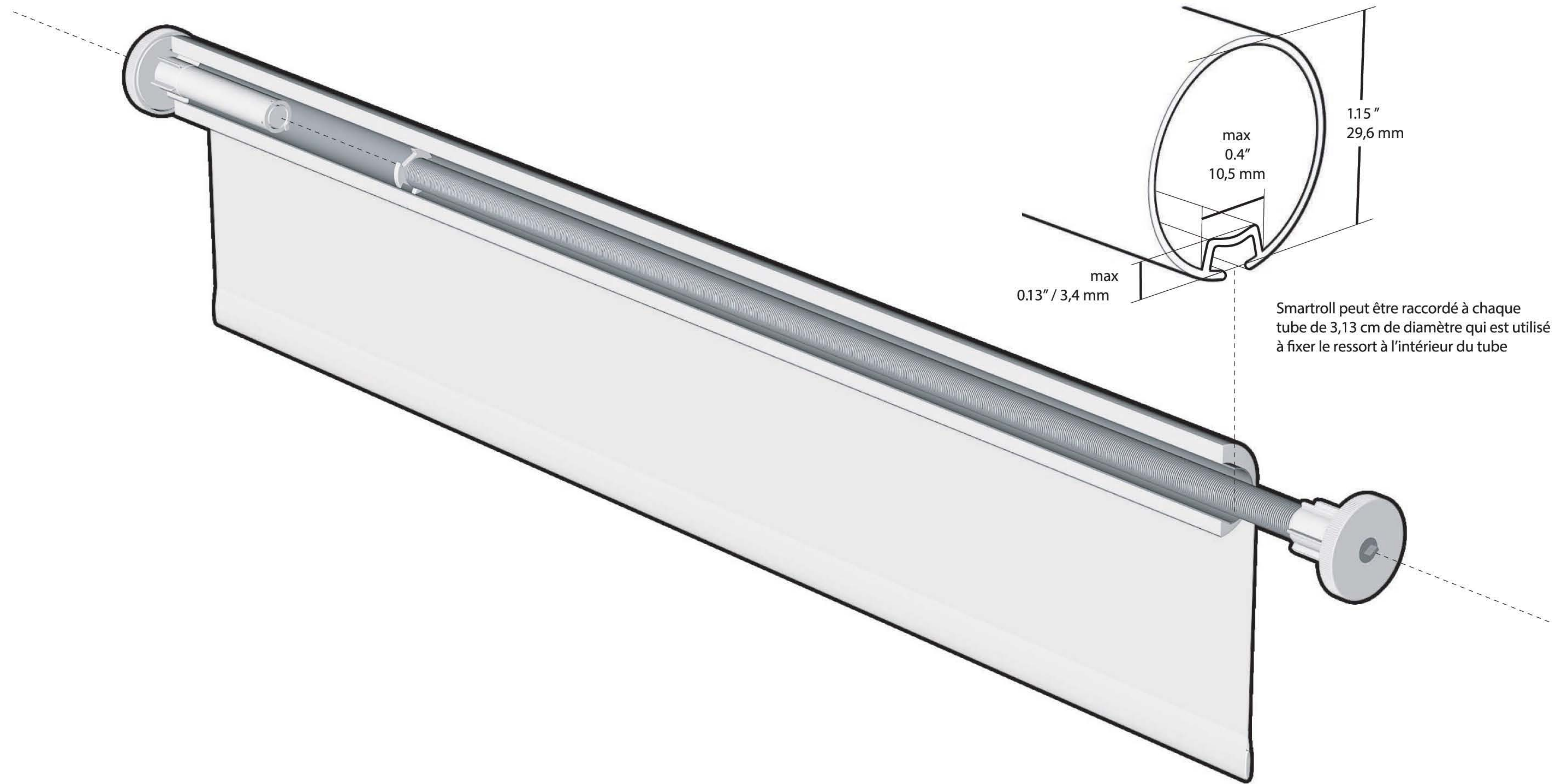

Caractéristiques techniques smartroll™ 32-2

## Poids maximum et dimensions du tissu

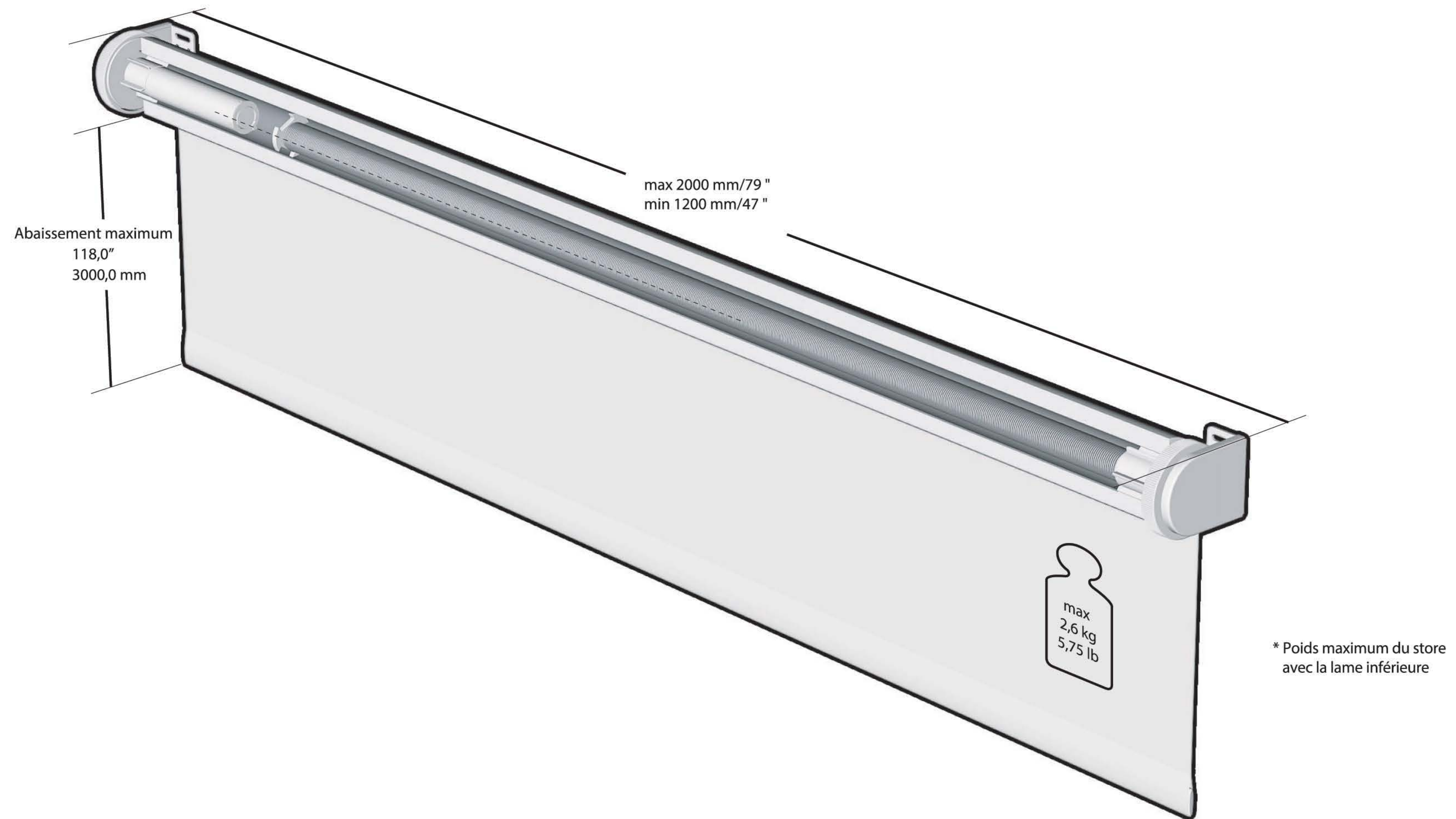

## Nombre maximum de tours



Largeur totale u tissu	Nombre de tours recommandé
120	12
140	13
160	14
180	15
200	16
220	17
240	18