

Características técnicas
de smartroll™ 32-2

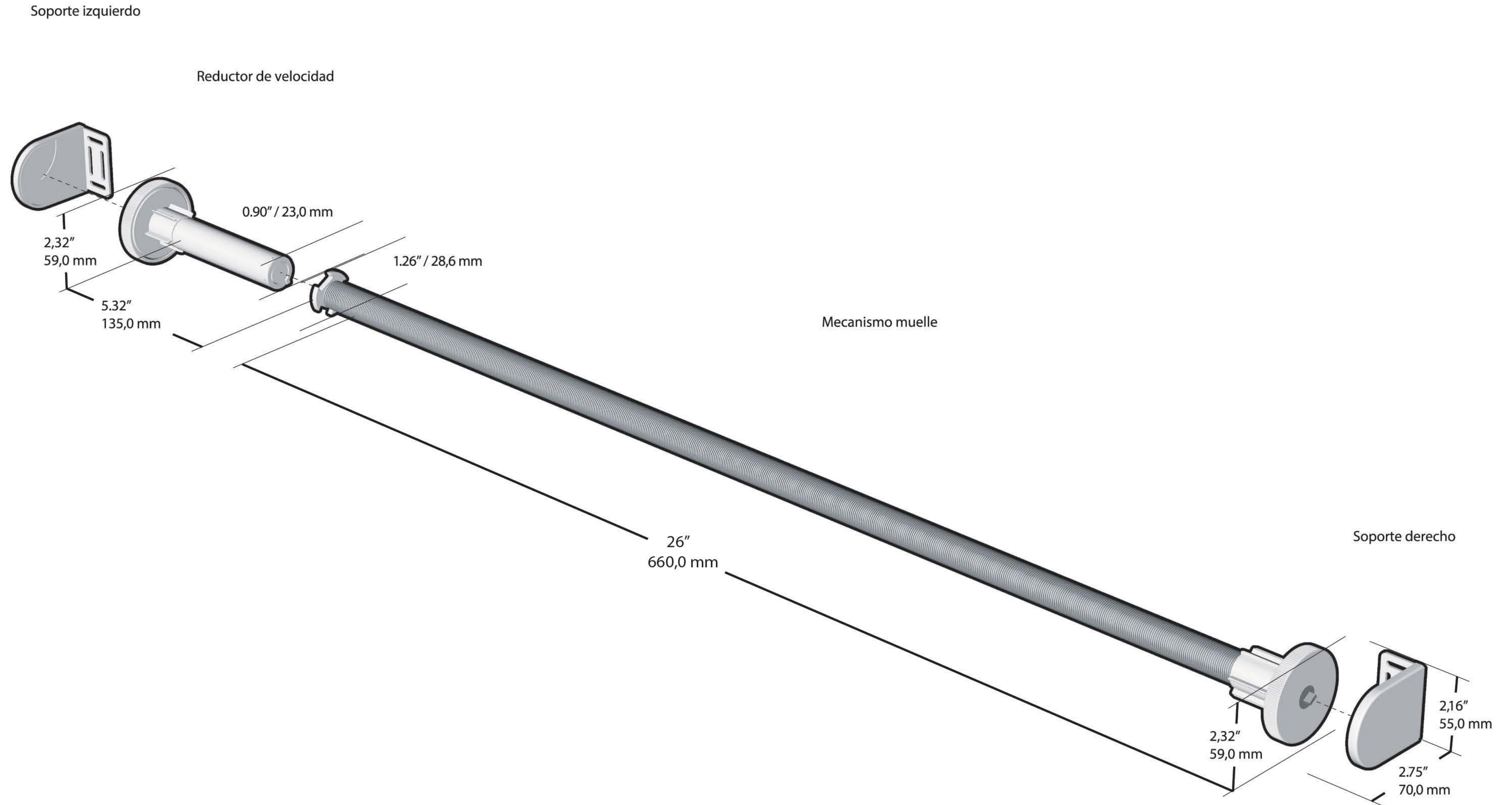

Particulars of the mechanism parts



Diámetro y perfiles del tubo

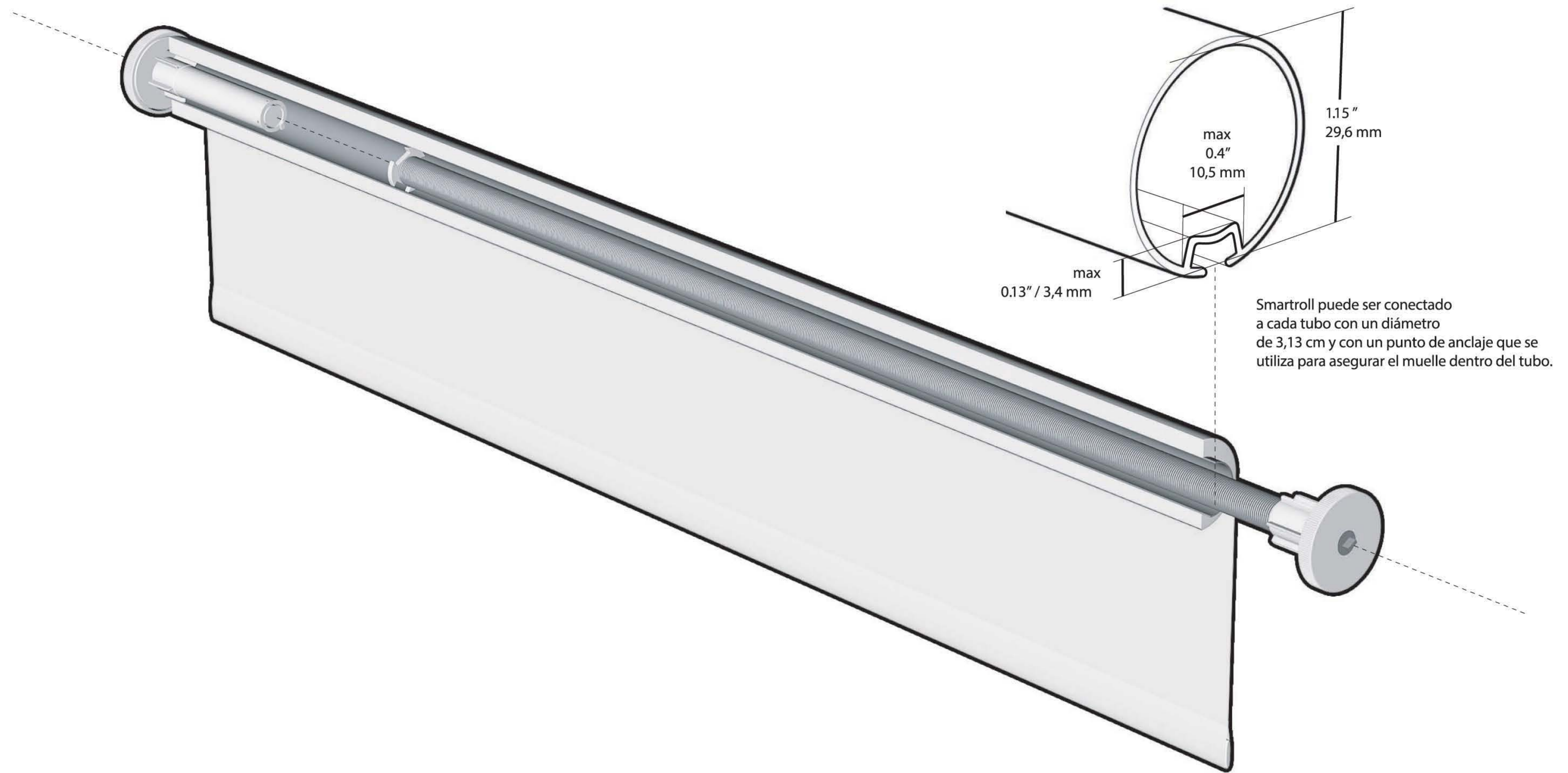

Características técnicas de smartroll™ 32-2

Peso y tamaño máximo del tejido

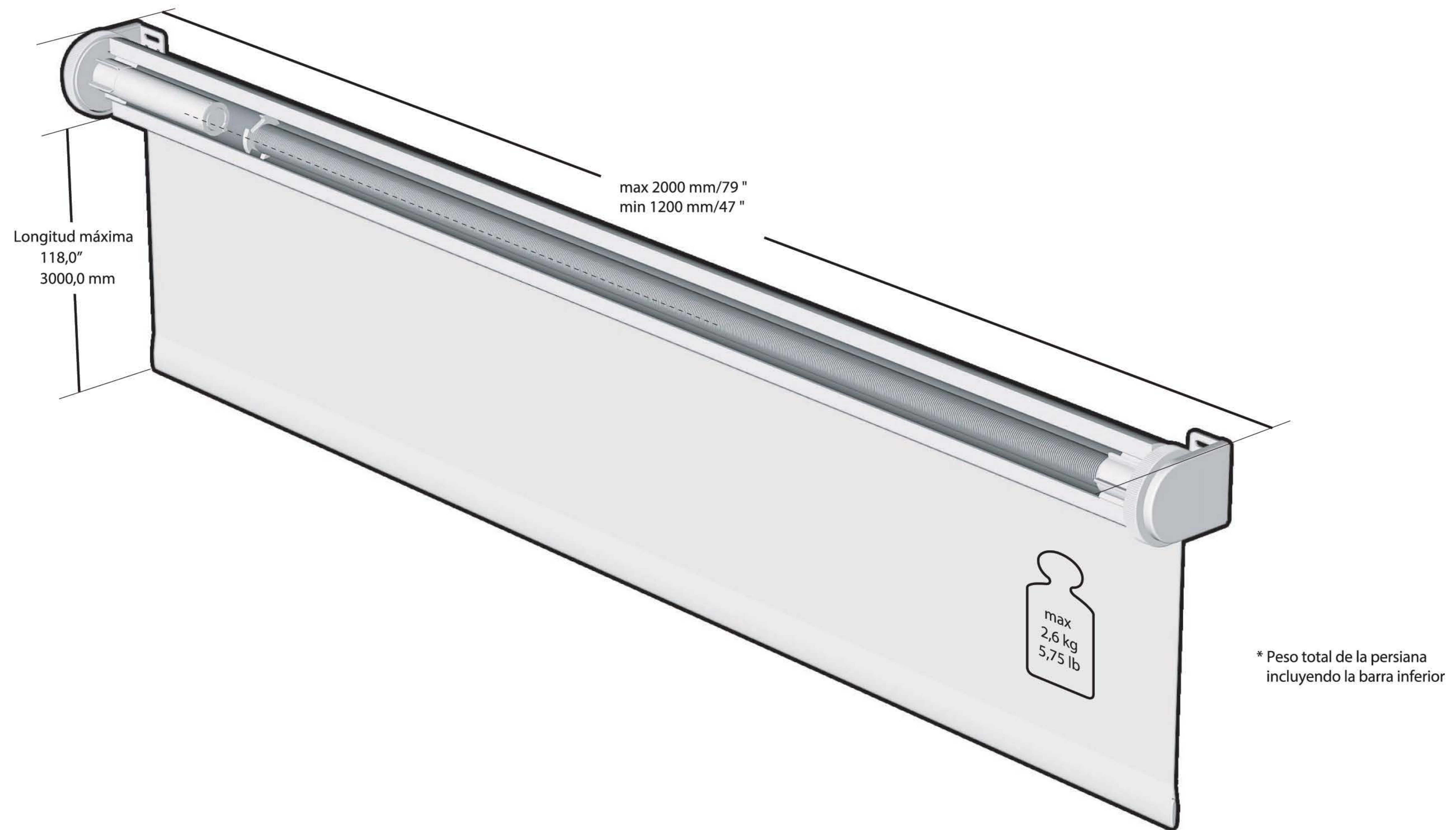

Número máximo de vueltas

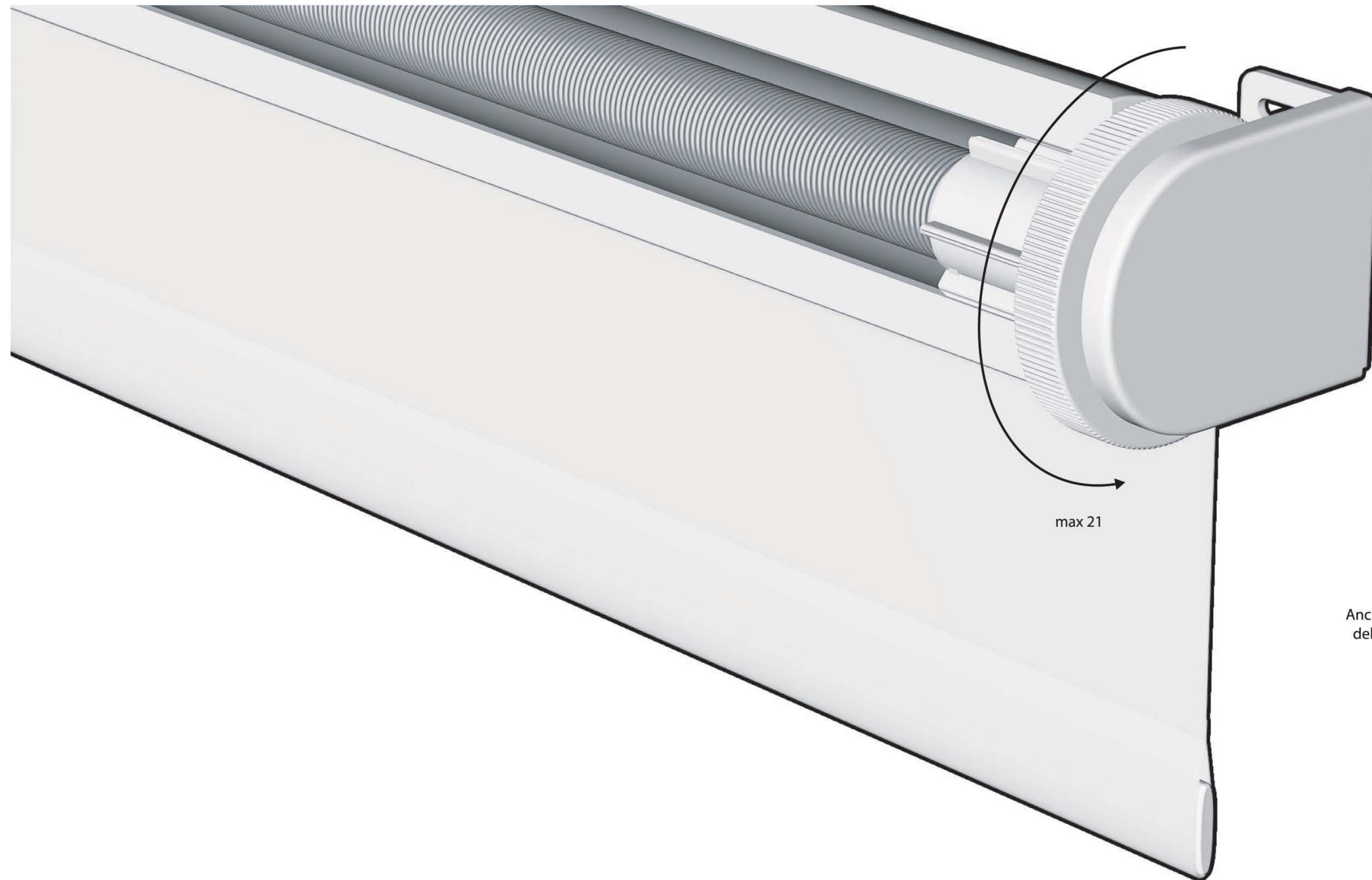

Ancho total del tejido	Número sugerido de vueltas
120	12
140	13
160	14
180	15
200	16
220	17
240	18