

Technical specification
of smartroll [™] 32-2

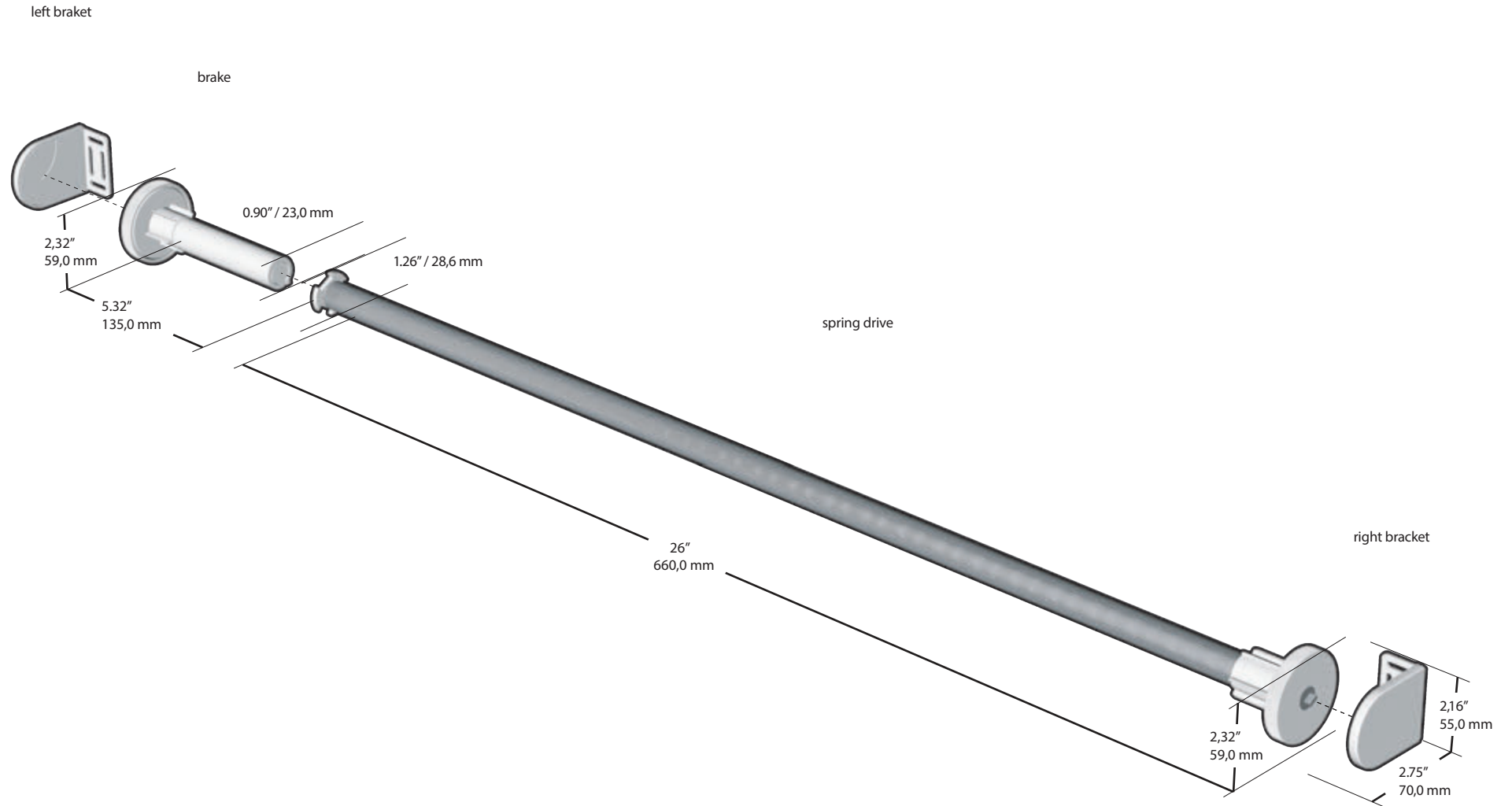

Particulars of the mechanism parts



Tube diameters and sections

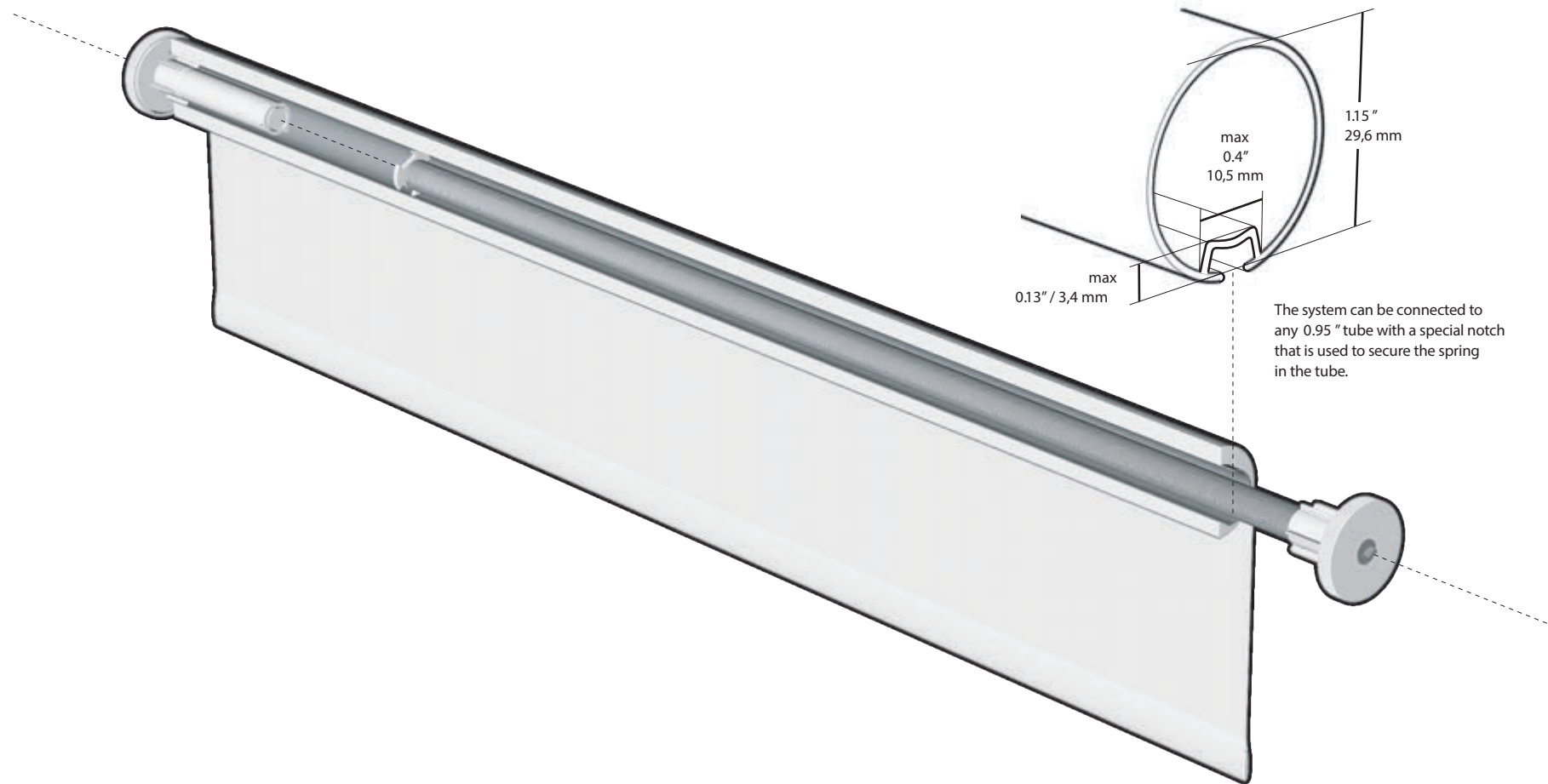

Technical specification of smartroll™ 32-2

Maximum weight and size of the fabric

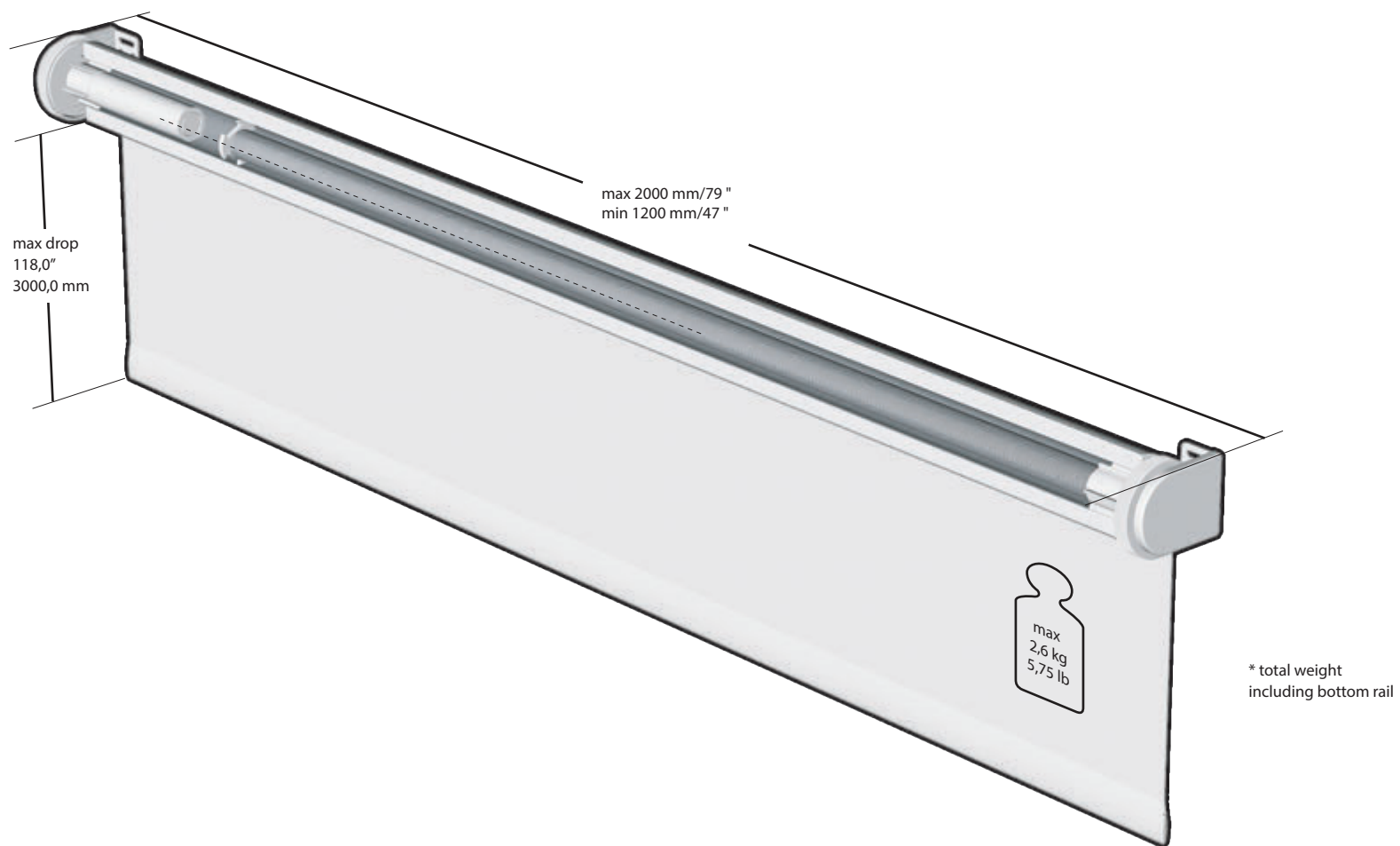

Technical specification of smartroll™ 32-2

Maximum number of windings

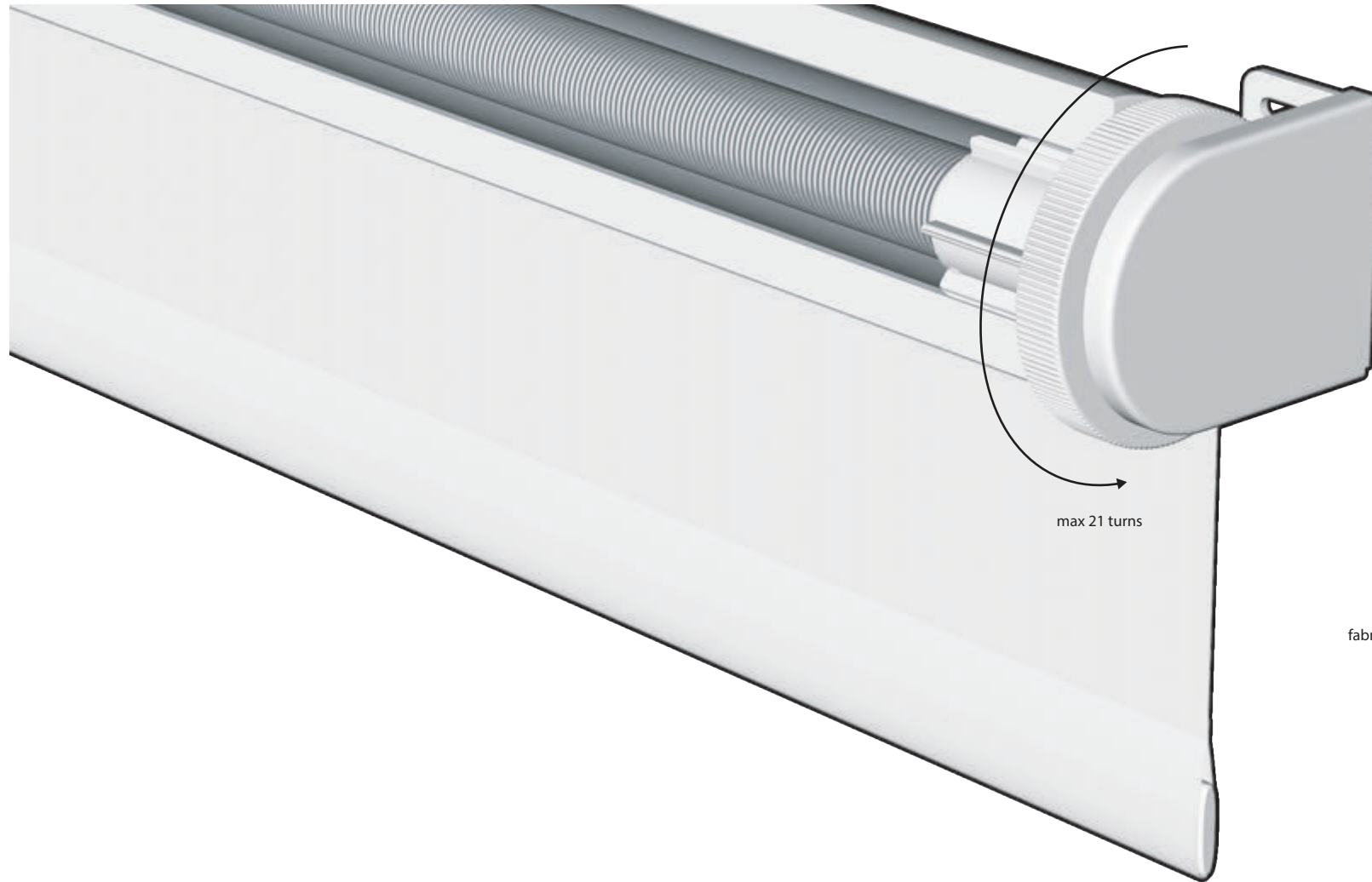

Total fabric width	Suggested number of turns
120	12
140	13
160	14
180	15
200	16
220	17
240	18