

Specyfikacja techniczna

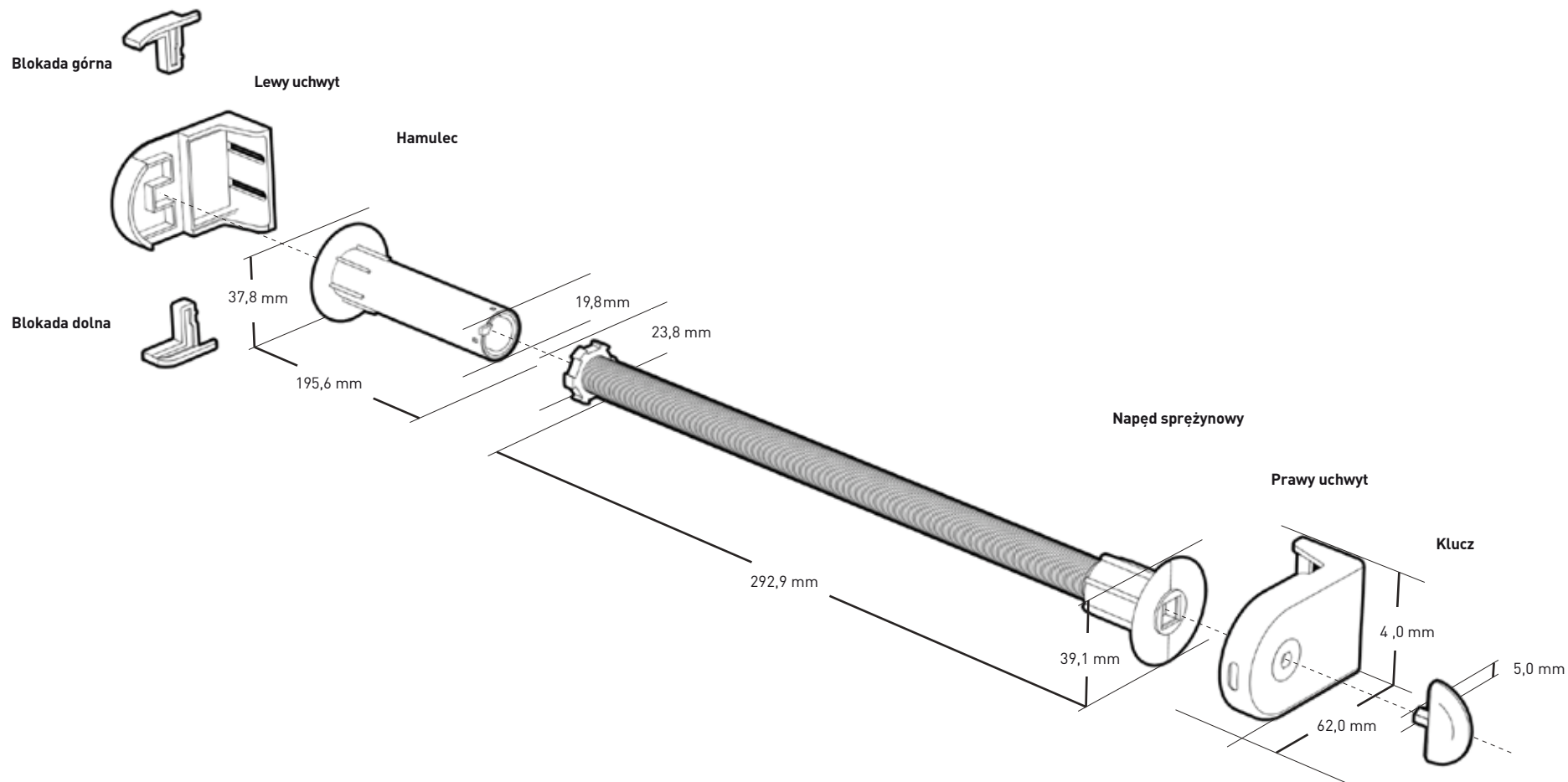

Szczegółowe dane o częściach mechanizmu



Profil i średnica rury

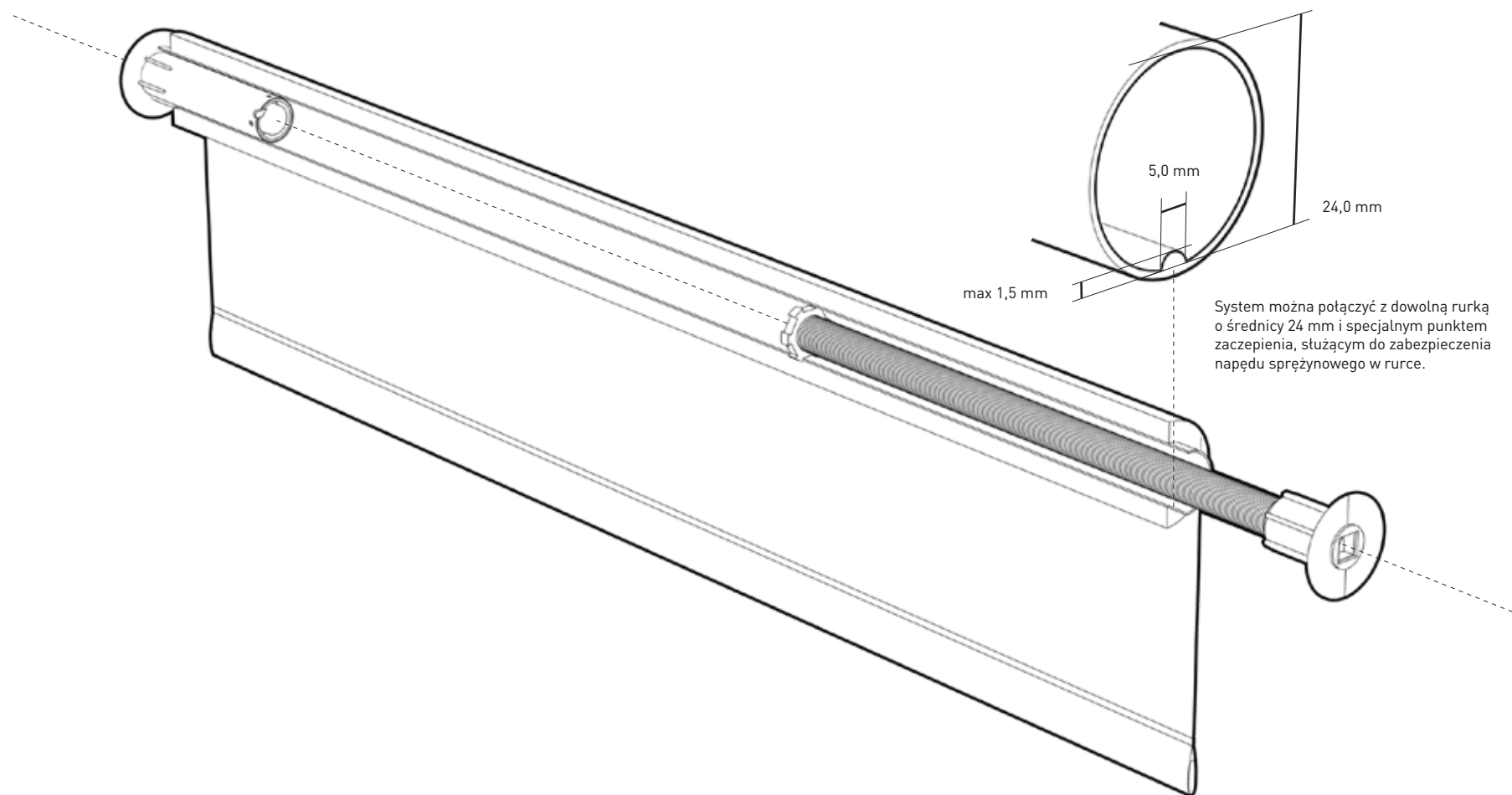

Maksymalna waga oraz rozmiar tkaniny

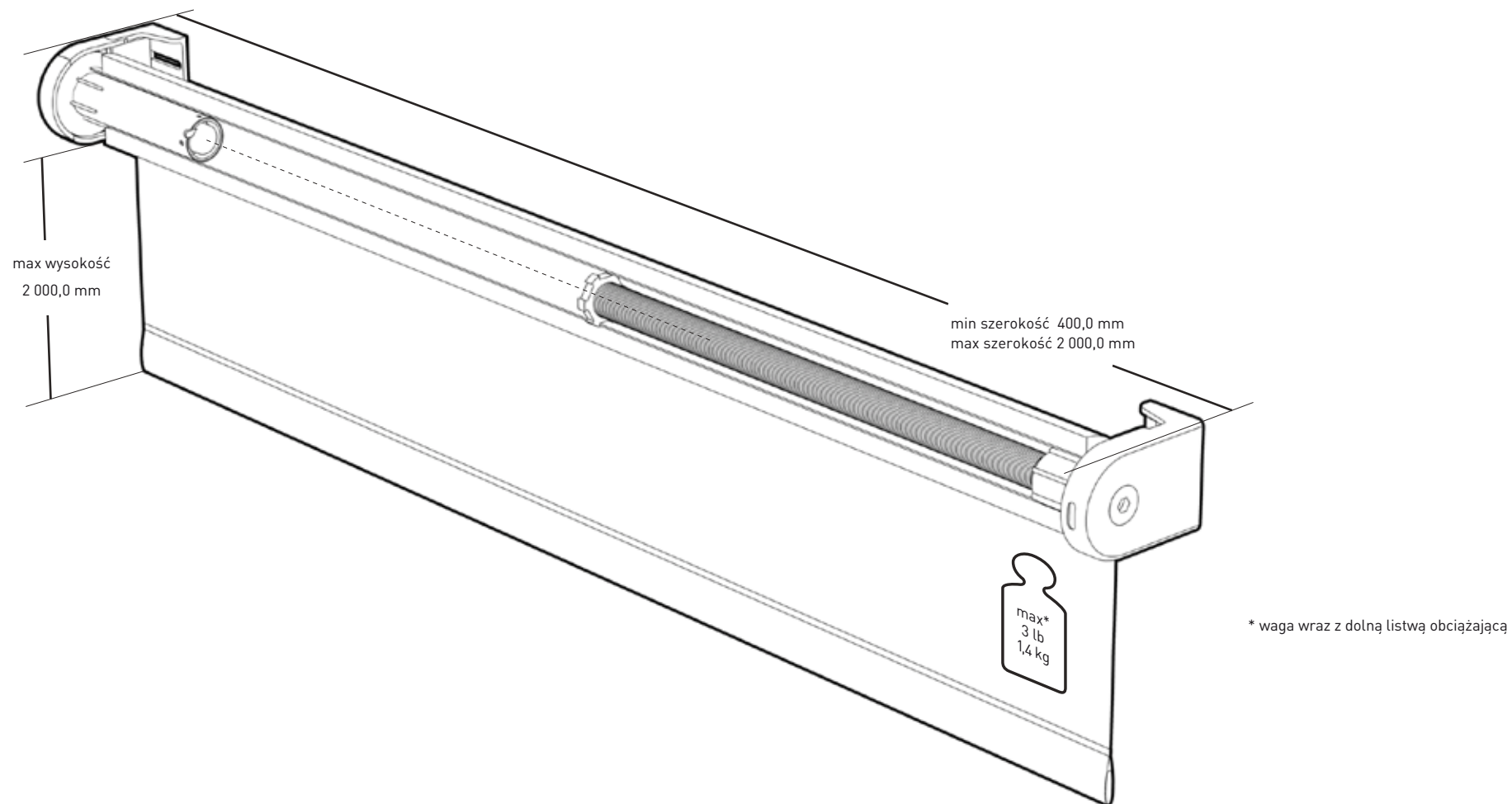

Maksymalna liczba nakręć

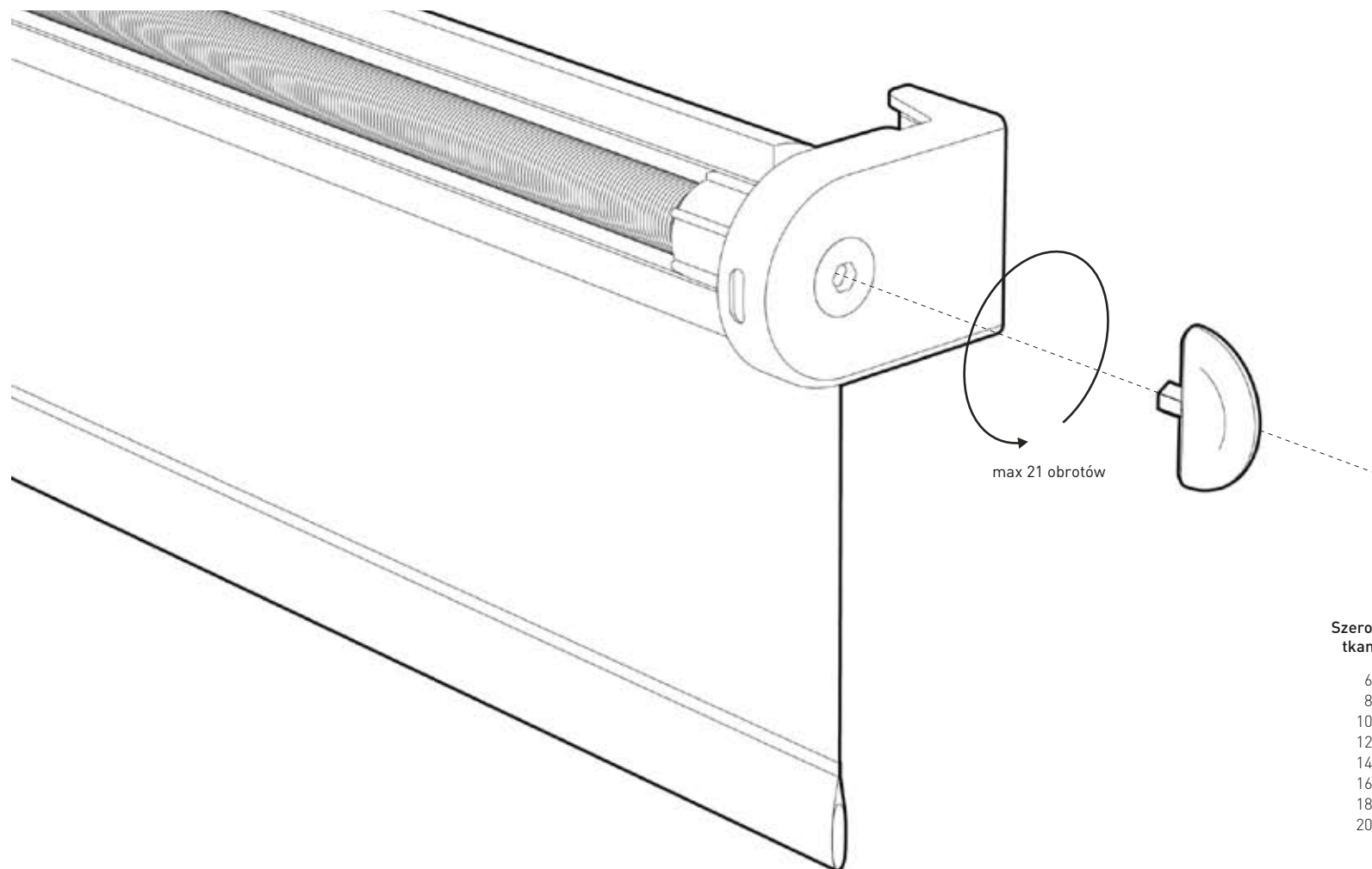

| Szerokość tkaniny | Sugerowana liczba obrotów |
|-------------------|---------------------------|
| 60 | 7 |
| 80 | 8 |
| 100 | 10 |
| 120 | 11 |
| 140 | 13 |
| 160 | 14 |
| 180 | 15 |
| 200 | 16 |

