

Technical specification

Particulars of the mechanism parts

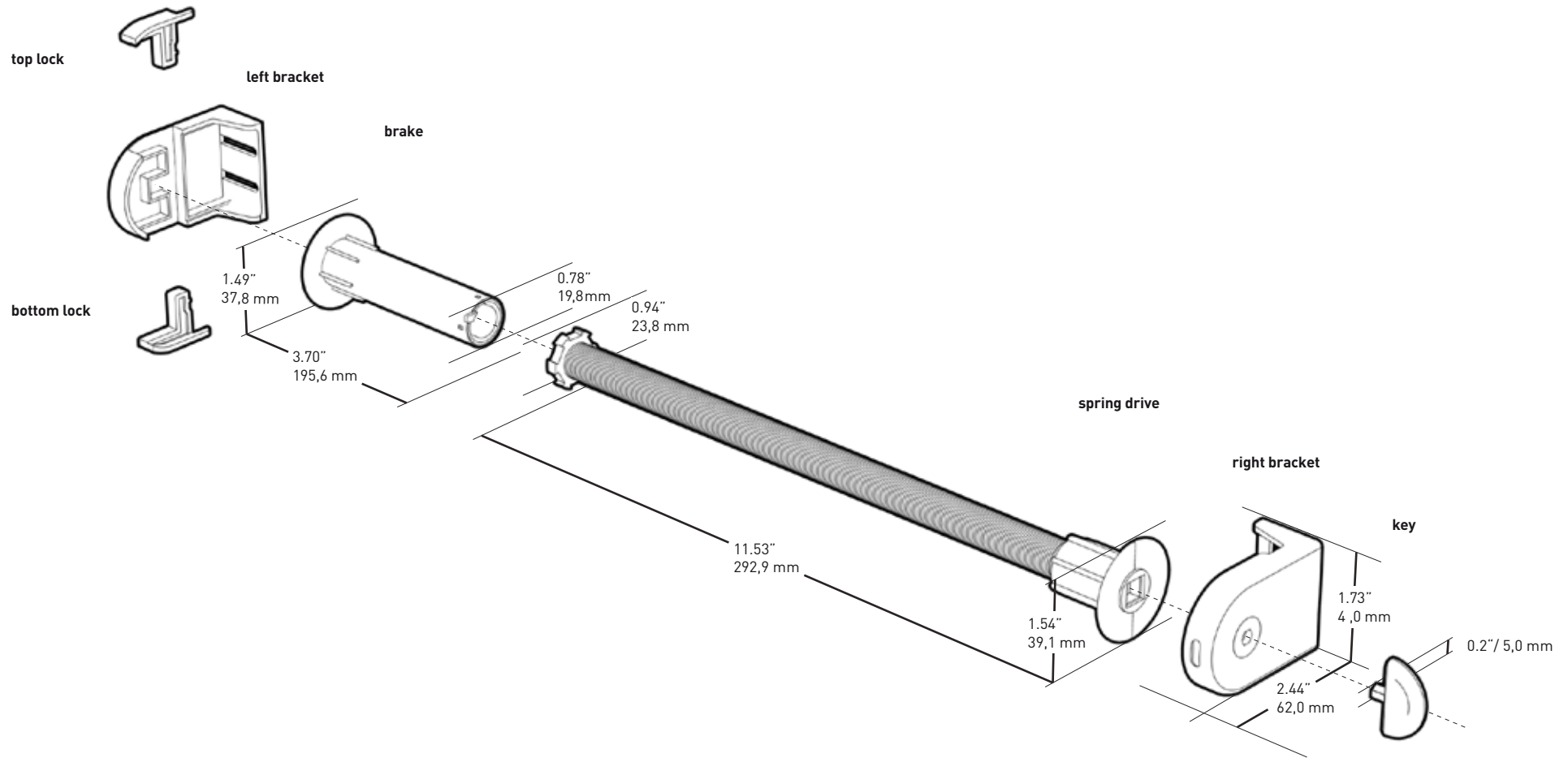

Tube diameters and sections

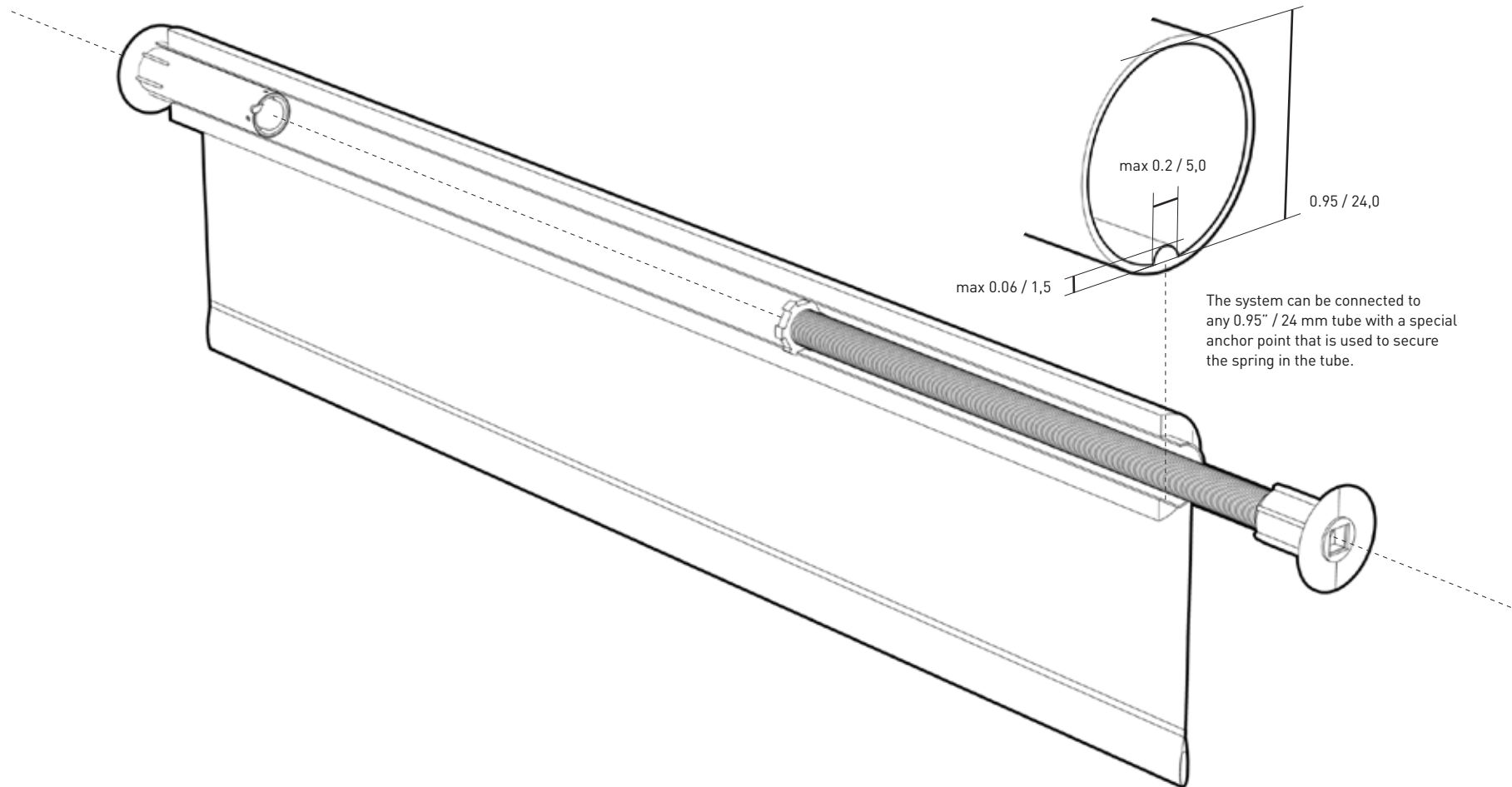

inch / mm

Technical specification

Maximum weight and size of the fabric

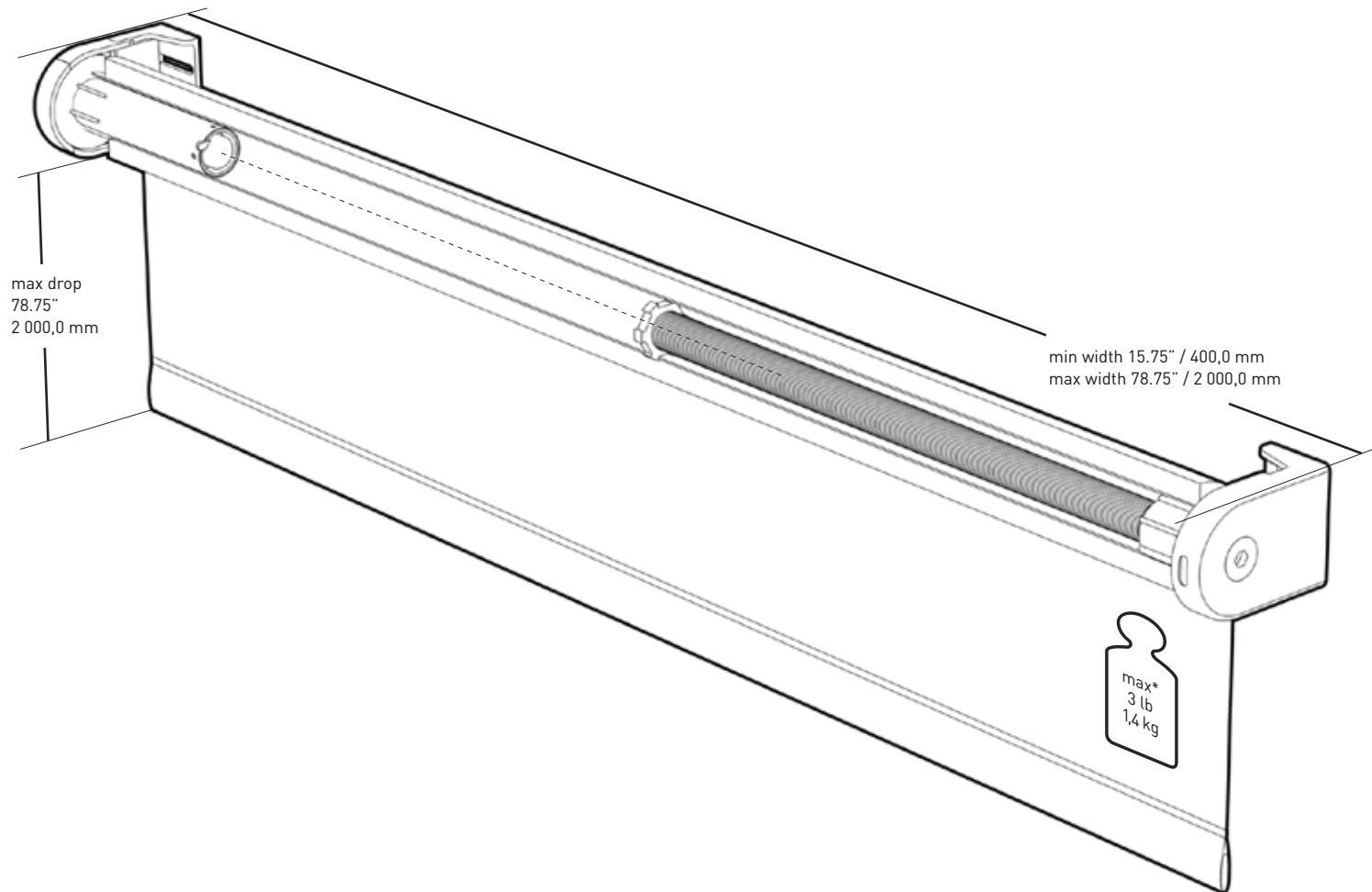

Technical specification

Maximum number of windings

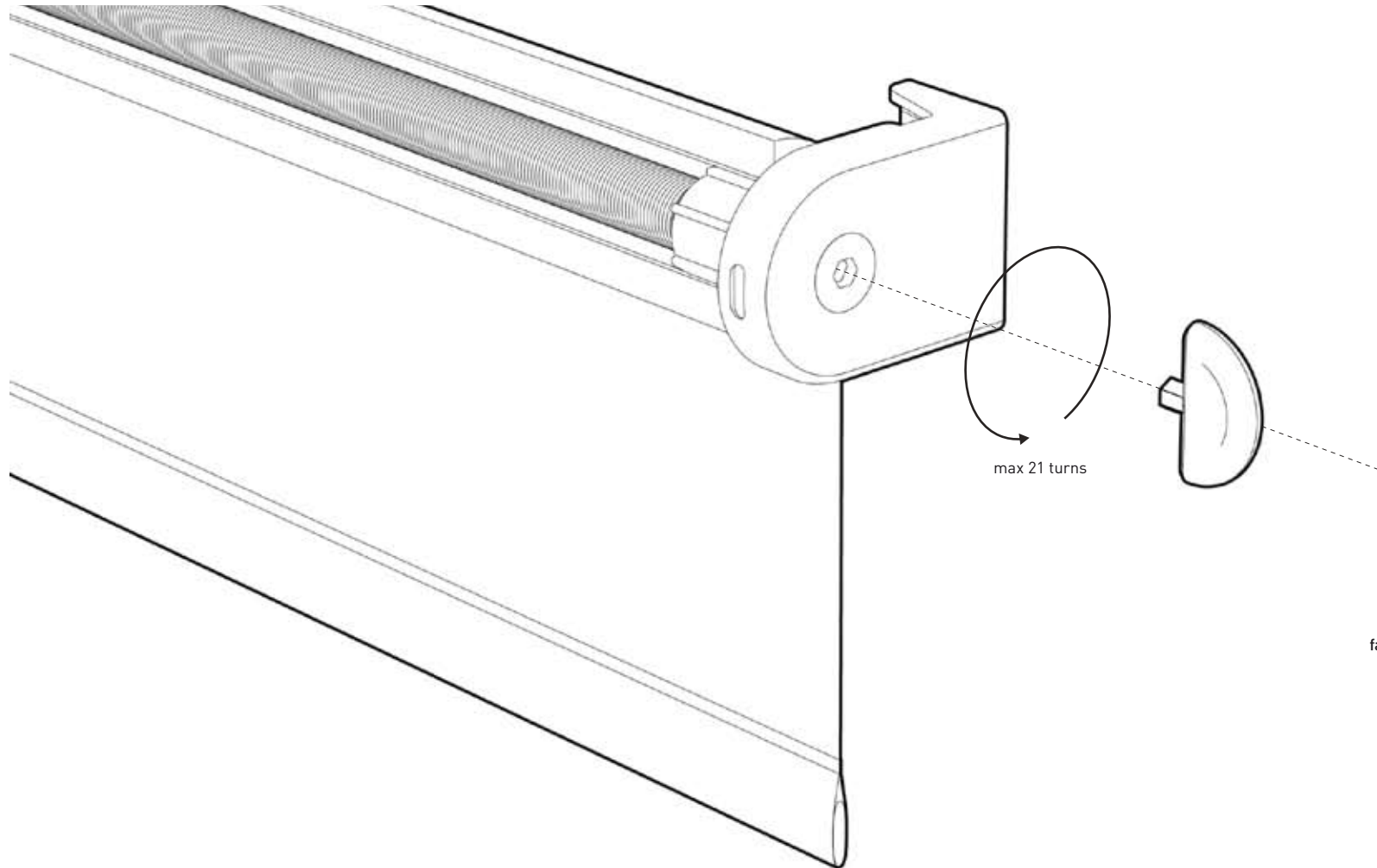

Total fabric width	Suggested number of turns
60	7
80	8
100	10
120	11
140	13
160	14
180	15
200	16

