

## Technische Spezifikation

# Einzelheiten der Teilen von Mechanik

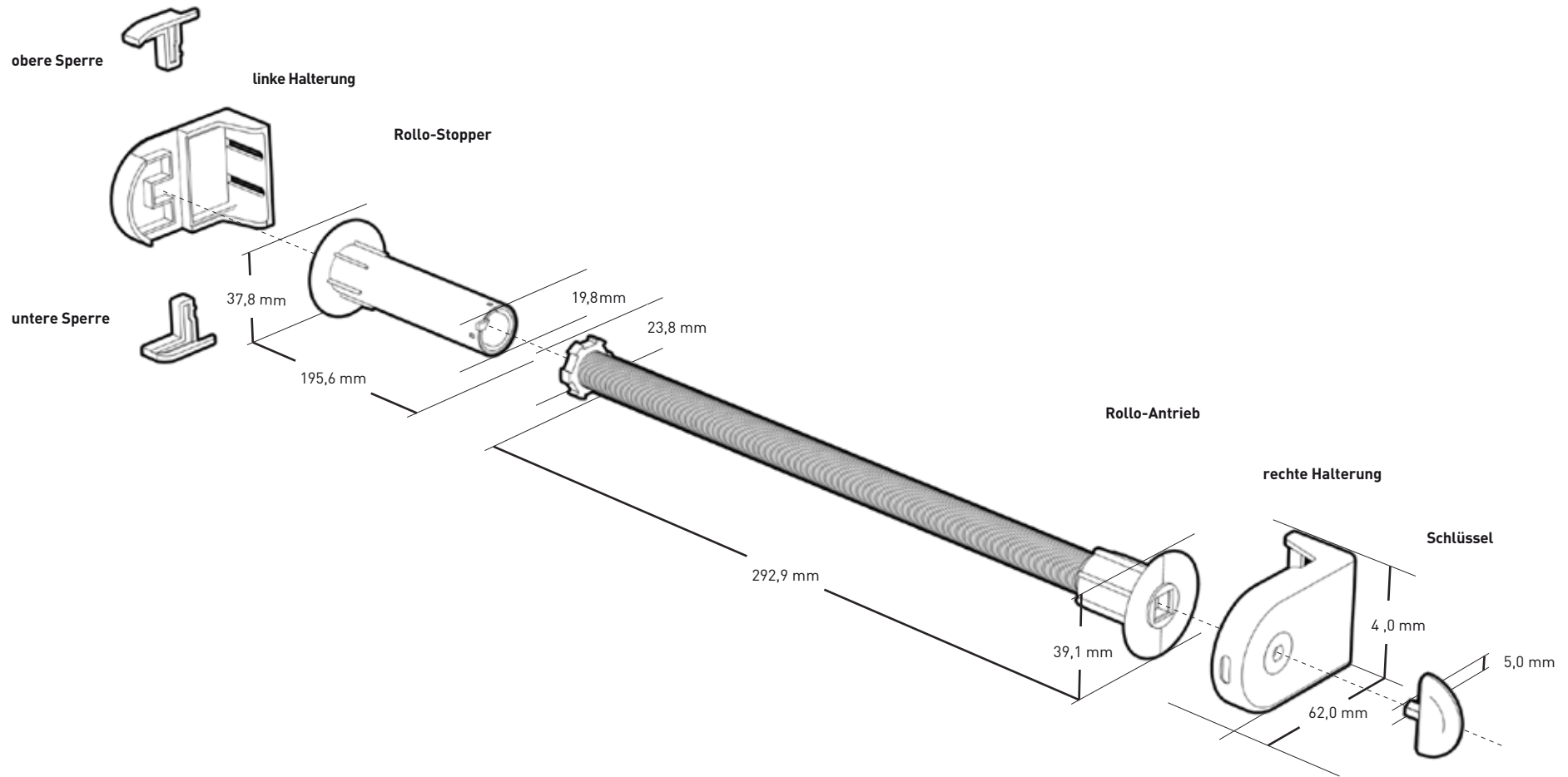

## Rohrdurchmesser und Abschnitte

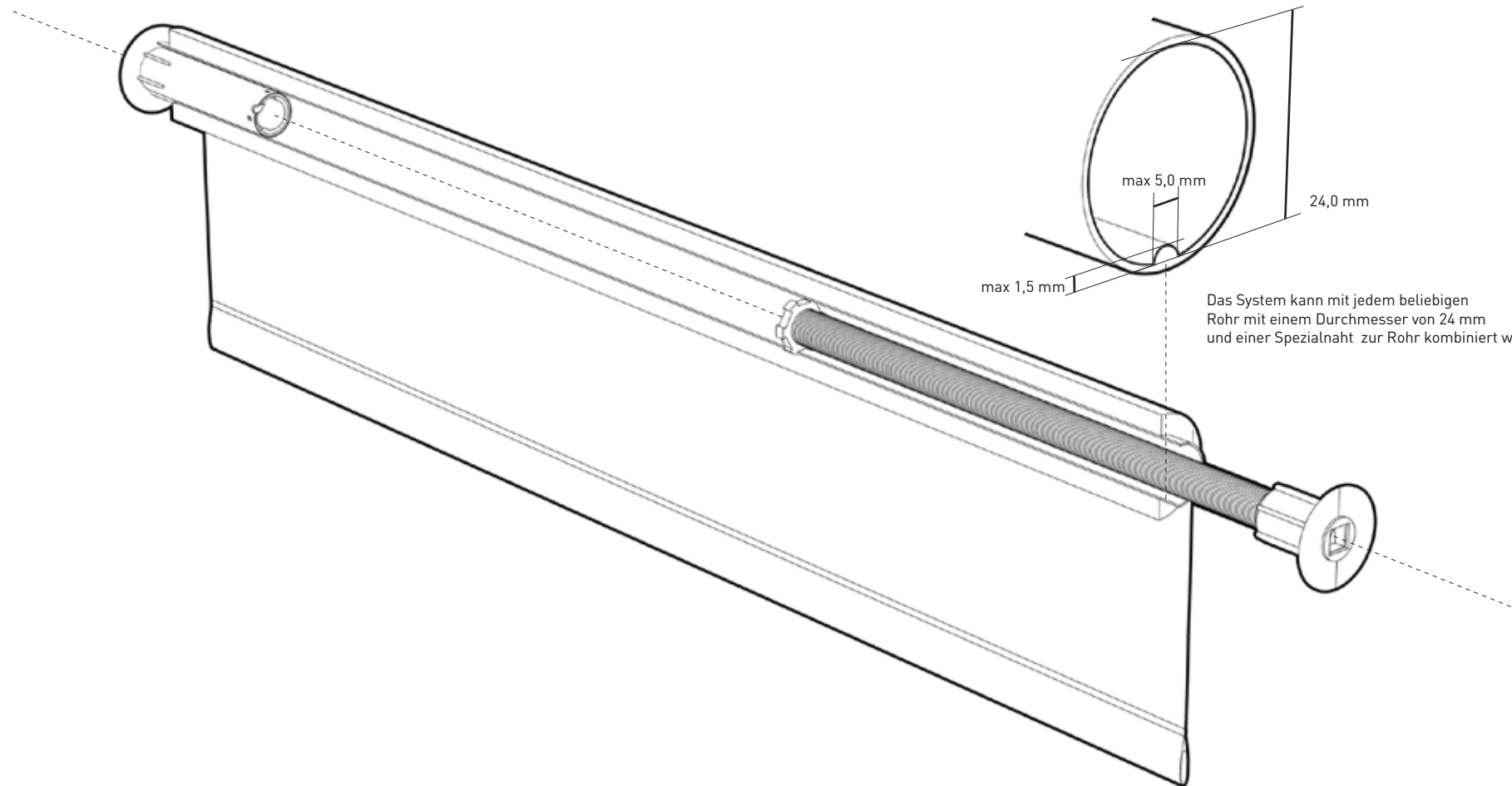

## Maximales Gewicht und Größe des Gewebes

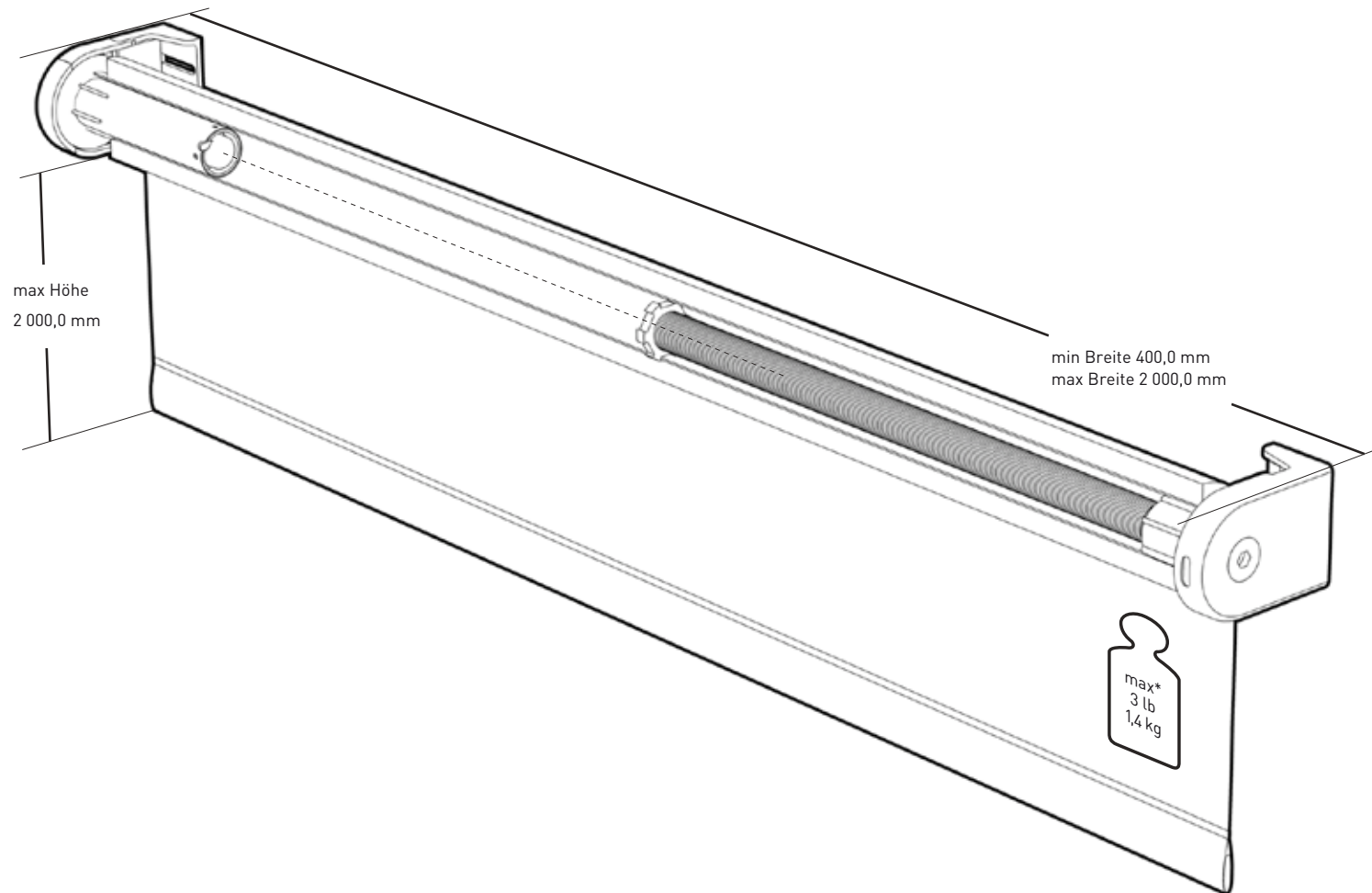

\*Gesamtgewicht inklusiv unterer Schiene

## Maximale Anzahl der Wicklungen

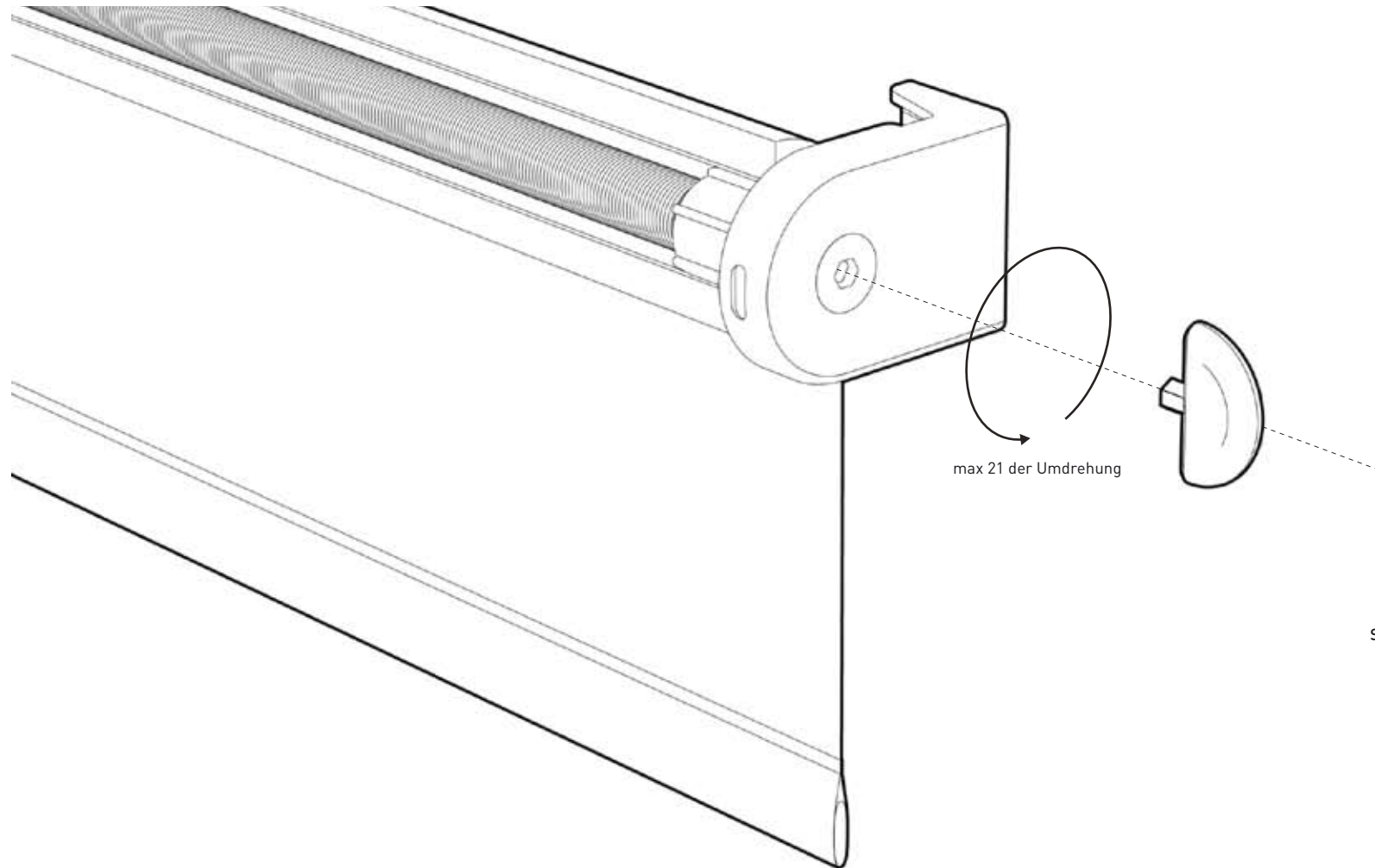

Stoffbreite	empfohlene Anzahl der Wicklungen
60	7
80	8
100	10
120	11
140	13
160	14
180	15
200	16

